

RENAULT

4  
fourgonnette

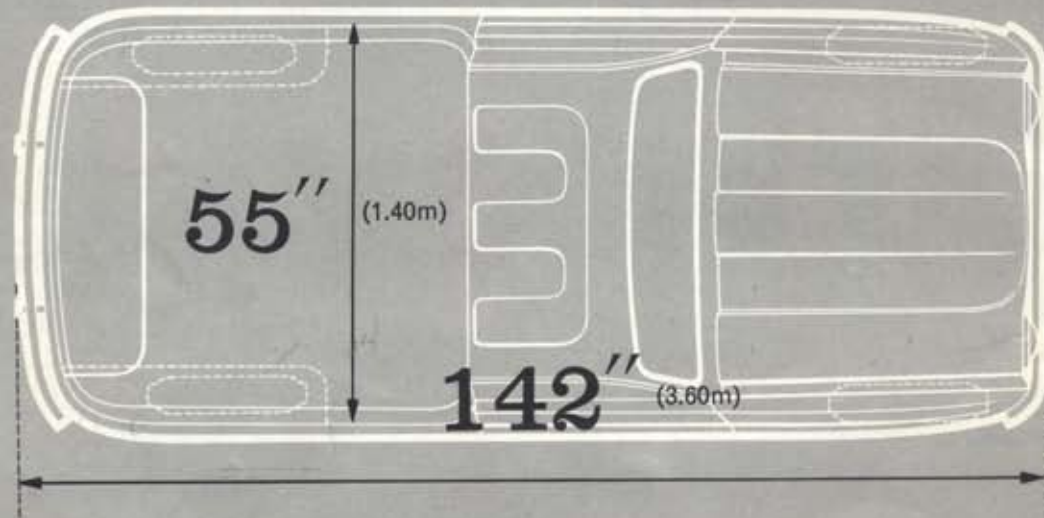

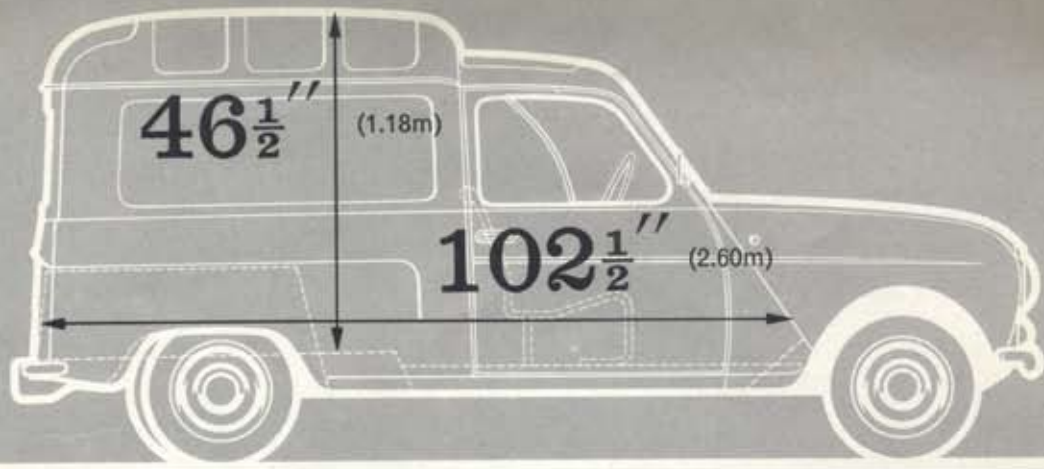

Total maximum weight authorised—  
18 3/4 cwt. (950 kg)

Kerb weight (complete with spare wheel and tool kit)—  
11 1/4 cwt. (575 kg)

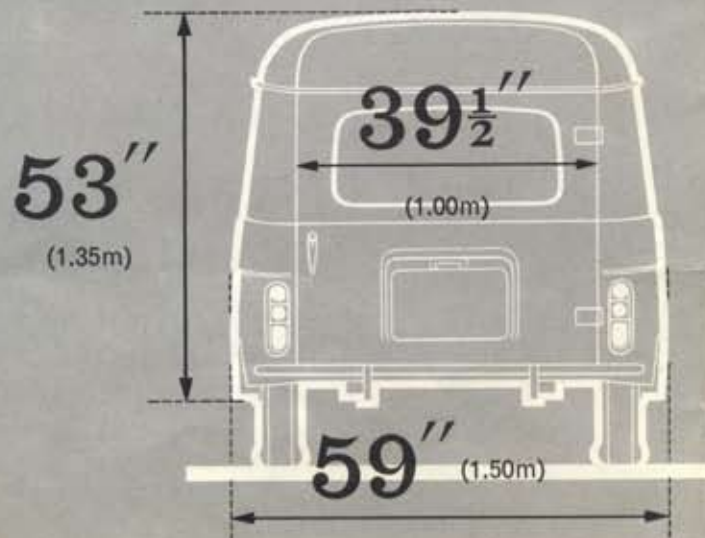

## 6-cwt. payload<sup>(300 kg)</sup>

Load up with anything. The R4 Fourgonnette can take it, no matter what, no matter where. With the flat under-surface of its floor, its high (adjustable) road clearance and, above all, its “all-roads” suspension, it can take the roughest tracks and go cross-country without harm either to itself or its cargo. You can push the Fourgonnette to the limit—it’s made for it.

*dress her up in your own colours*





## 66½ cu. ft. load space<sup>(1.88 m<sup>3</sup>)</sup>

... and 100% usable, for there's not an inch wasted in the Fourgonnette. Better still, you can gain yet more space (by removing the passenger seat) and carry overlength items (thanks to the roof-flap over the rear door). The R4 Fourgonnette is truly 'supercapacious'.

86 sq. ft. (8m<sup>2</sup>) for free advertising



## 16 sq. ft. of usable surface<sup>(1.50m<sup>2</sup>)</sup>

You load and unload very easily: low, flat floor, wide service door (always fitted to open away from the pavement) with a catch to keep it fully open while you work. The suspension takes great care of fragile articles—without special packing—without risk of breakage—without anxiety.

dress her up in your own colours





(95 km/h)

## Touring comfort at 56 m.p.h.

Everything for the driver's comfort; very resilient, adjustable seats—plenty of leg-room—pendant-type pedals—dished-type, safety steering wheel—non-reflecting instrument panel—huge parcel shelf—indicators and stop-lights grouped together—very efficient SOFICA heater and demister—passenger seat (optional extra). A very special vehicle.

*dress her up in your own colours*



## 28 ft. turning circle<sup>(4.50 m)</sup>

With its precise steering, it can be handled to a hairsbreadth, slipping through the worst traffic jams and the narrowest lanes, parking anywhere thanks to a tight turning circle and the curved sliding front window that allows the driver free head movement when reversing and parking. It's a dream of a van for town deliveries—whatever the parking problem.

*86 sq. ft. (8 m<sup>2</sup>) for free advertising*





and, with panel windows . . .

. . . the R4 Fourgonnette is the truly dual-purpose light vehicle that many tradesmen need both for work and leisure. Weekdays, with the rear bench folded forward, it quickly deals with daily deliveries and takes tender care of fragile merchandise. It is smart to look at and offers all-round visibility through its 18½ sq. ft. (1.71m<sup>2</sup>) of surrounding window area.

*dress her up in your own colours*



. . . a family week-ender

After work the panel-windowed R4 Fourgonnette takes to the country. With its wide rear bench seat opened out, it's an ideal week-ender. Carries everything: children, dog, all your luggage – with space to spare. Speeds along at over 60 m.p.h. (100 km/h), takes rough surfaces smoothly and provides a flood of light through its large windows.

*86 sq. ft. (8m<sup>2</sup>) of free advertising space*



# fool-proof power unit,

FINR

Engine: 4-cylinder, 4-stroke, capacity 845 c.c. Compression ratio: 8:1. Removable wet liners. Maximum B.H.P: 32 SAE at 4,7000 r.p.m. Renault 4 CV engine, proved and tested over 14 years, has been rejuvenated and modernised. Gearbox: 3-speed (fully synchromesh) and reverse, gear lever mounted on dash. Front-wheel drive. Tyres: 145 x 330 low pressure or 135 x 330 radial corded. Bodywork and power unit bolted to a genuine chassis. Brakes: hydraulic with pressure regulator. Steering: rack and pinion. Spare wheel stowed in a special position under floor. Suspension: independent on all four wheels. Front:- 2 longitudinal torsion bars with maximum flexibility and 1 transverse anti-roll torsion bar. Rear:- 2 transverse torsion bars. 4 hydraulic telescopic shock absorbers. Together they ensure perfect road holding on corners and an extraordinary resistance to shock; no rolling—no pitching—no nose-lift on starting—no plunging on braking.

No water: cooling by closed circuit, filled with a special liquid containing anti-freeze and rust inhibitor, and sealed for life at assembly. No risk of freezing—no anti-freeze needed—no topping-up. No greasing: all that is needed is to check the engine and gearbox oil level from time to time and to drain the sump every 3,000 miles (5,000 kms).

10,000 Renault Agents are at your service throughout the whole world. Like all Renaults, the Fourgon 6 cwt. van carries the full Renault guarantee. The Régie Renault reserves the right to modify its models without prior notice, likewise their characteristics, equipment and accessories. Régie Nationale des Usines Renault, 8 Avenue Emile Zola, Billancourt, Seine, France. Tel: 408-13-13.

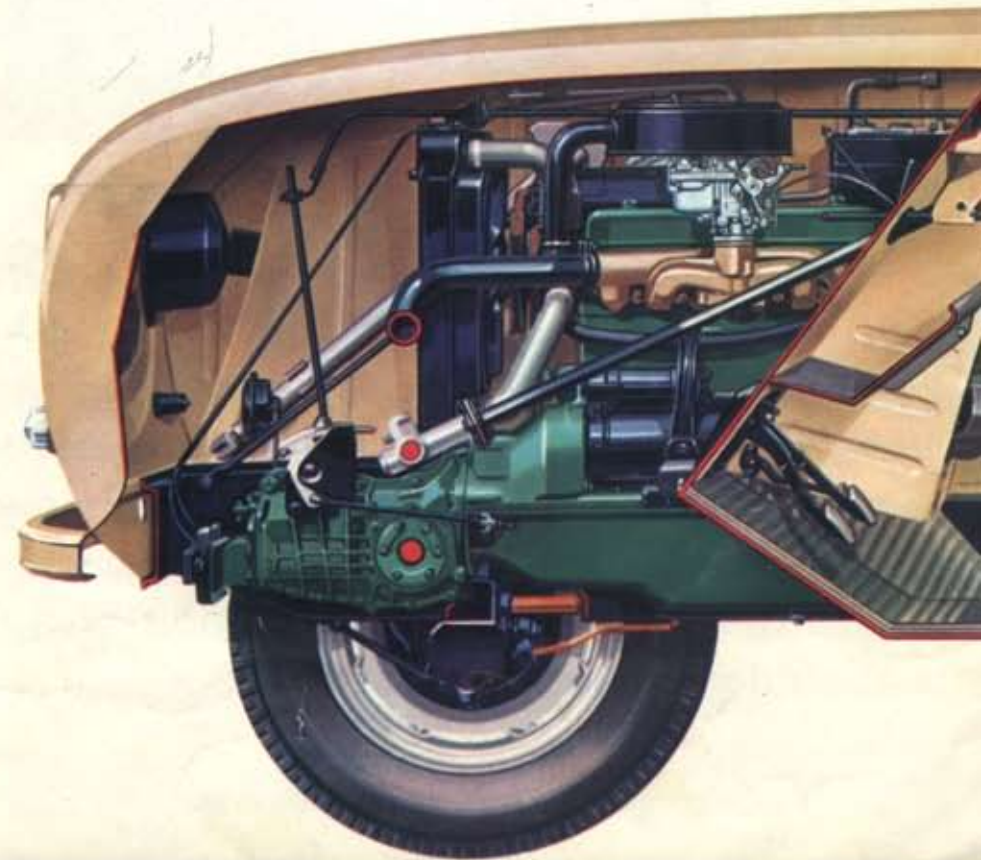

**economy all the way**

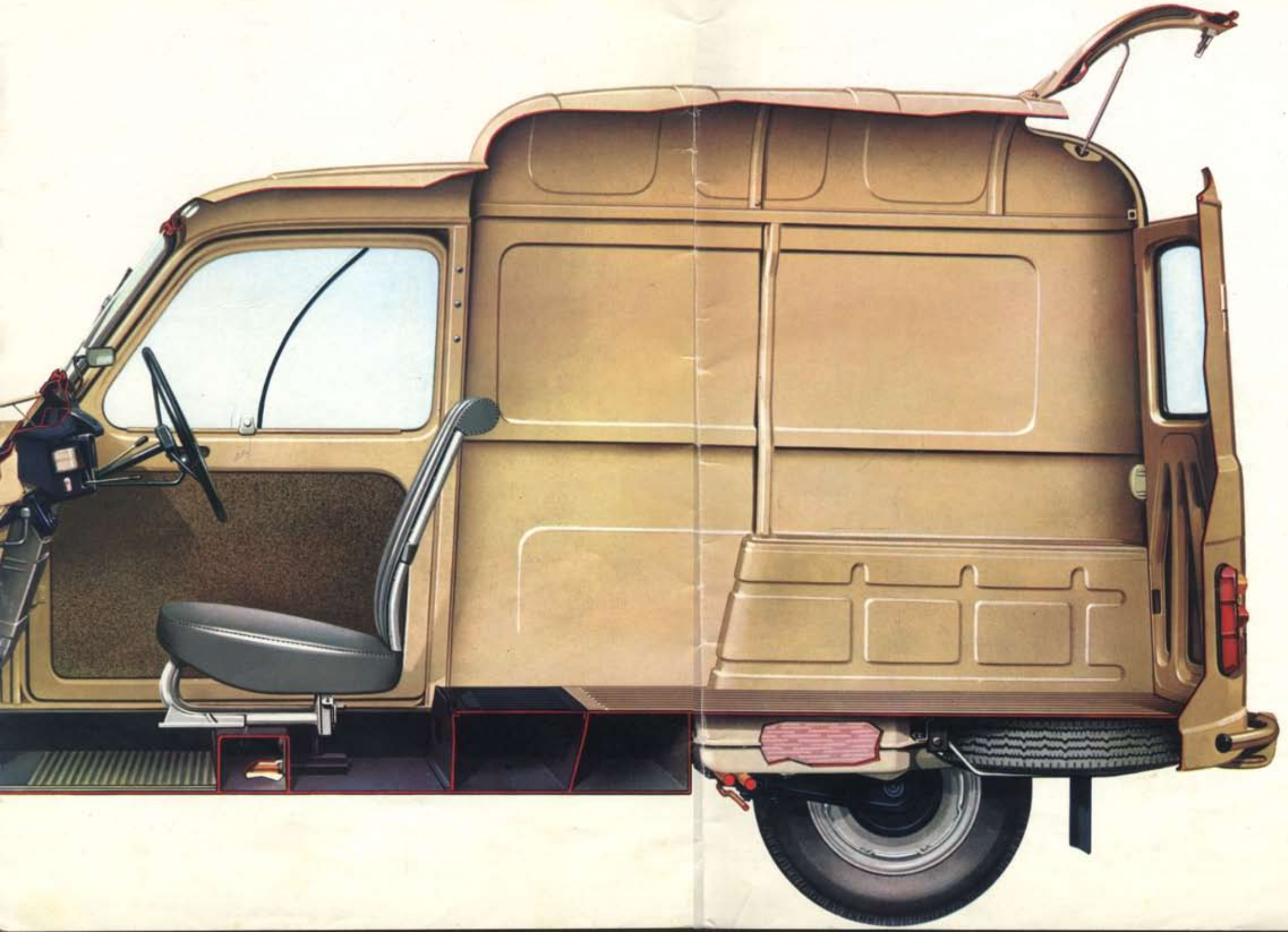

RENAULT

**4**  
fourgonnette

